

BIOCOOLERS

 **BIOCOOL**

ECO Cooling Solutions

PORTABLE COOLERS GUIDE
WIND FORCE SERIES



2

GUARANTEE
COMPONENTS
YEARS



ASSAMBLED IN ITALY
Version v.2021

INDEX

- Safety information3
- Unpacking5
- Description5
- Operation5
 - 4.1. Switch-on6
 - 4.2. Functions of the control panel and remote control7
 - 4.3. Switch-off7
- Cleaning and maintenance8
 - 5.1. Tank8
 - 5.2. Evaporative panels and water circuit8
 - 5.3. Air filter9
- Troubleshooting10
- Technical specifications11
- Pictures12

1. SAFETY INFORMATION

⚠ IMPORTANT: READ AND UNDERSTAND THIS OPERATIONAL MANUAL BEFORE ASSEMBLING, COMMISSIONING OR PERFORMING MAINTENANCE ON THIS APPLIANCE. INCORRECT USE OF THE APPLIANCE CAN CAUSE SERIOUS INJURY. KEEP THIS MANUAL FOR FURTHER REFERENCE.

⚠ IMPORTANT: THIS APPLIANCE IS NOT SUITABLE FOR USE BY PERSONS (INCLUDING CHILDREN) WITH REDUCED PHYSICAL, SENSORY OR MENTAL CAPACITIES OR WHO LACK EXPERIENCE OR KNOWLEDGE UNLESS SUPERVISED BY A PERSON RESPONSIBLE FOR THEIR SAFETY. CHILDREN MUST BE SUPERVISED TO MAKE SURE THEY DO NOT PLAY WITH THE APPLIANCE.

- 1.1.** Only fill the cooler tank only with clean water.
- 1.2.** Before carrying out any operation, make sure the cooler, including the power supply cable and the control panel are perfectly dry, in order to avoid any risk.
- 1.3.** After filling the tank, handle the cooler carefully.
- 1.4.** Comply with all local legislation and current regulations when using the cooler.
- 1.5.** Keep the cooler dry, in order to avoid electric shocks. Hands must always be dry.
- 1.6.** Use only in ventilated and dry areas.
- 1.7.** Only power the cooler with the voltage and frequency as specified on the nameplate.
- 1.8.** Do not cover the cooler with paper, cardboard, plastic, metal sheets or any other inflammable material during use, in order to prevent any risk.
- 1.9.** The cooler must be used on a stable and levelled surface, in order to prevent any risk.
- 1.10.** Disconnect the cooler from the mains power supply when not in use.
- 1.11.** Never block the cooler’s air vents or the air outlet.

1.12. The minimum safety distance recommended between the cooler and walls or other items is 0.5 m.

1.13. Never move, handle, refuel or conduct maintenance on the cooler when it is connected to the mains or in operation.

1.14. The cooler (power cable included) must be kept at a suitable safety distance from heat sources.

1.15. In any case, the cooler must be opened and/or repaired by authorised after-sales centre.

1.16. If the power supply cable is damaged, it must be replaced by a technical support centre to prevent any risk.

1.17. In the event of incorrect cooler operation, immediately disconnect the electrical power supply and contact the support centre.

1.18. Protect the power cable from potential damage caused by the movement of vehicles or pedestrians. Improper connection to electrical voltage or improper installation may result in electric shocks.

1.19. Conditions of use:

- A) Temperature of the air: 18°C - 45°C; Temperature of the water: <45°C.
- B) The air must be free of dust and pollutants, otherwise cleaning

1.21. The water used to fill the cooler tank must come from an aqueduct. If it is not possible to draw from an aqueduct, the water introduced must be subjected to a sanitation treatment, according to European Directive 98/83/EC.

- We recommend using water with a hardness of less than 15°f.
- The cooler tank must be emptied and sanitised periodically depending on the use.
- The evaporative panel surfaces must be periodically inspected and sanitised depending on the use.
- For sanitation operations, biocidal products that comply with European regulation no. 582/2012 must be used.

2. UNPACKING

2.1. Remove all packaging material used to pack and deliver the cooler and dispose of it in compliance with current standards.

2.2. Check for any damage incurred during transport. If the cooler appears damaged, immediately inform the dealer from whom it was purchased.

3. DESCRIPTION

The evaporation coolers cool the air by using the natural process of water evaporation. Operation of these air coolers is based on evaporative cooling that uses the energy exchange between the water and air.

The coolers consist of an evaporative panel, a fan and a cascade water distribution system. The fan draws air from outside and passes it through the evaporative panel, which is made entirely of cellulose and is constantly wet by a special system that pumps water.

4. OPERATION

 **WARNING:** Carefully read the "SAFETY INFORMATION" before switching on the cooler.

 **WARNING:** Only use clean water to prevent failures or other anomalies.

 **WARNING:** Verify if your wiring system is earthed correctly. Connection to the mains must be made in compliance with the National Standards in force. Only power the cooler with the voltage and frequency as specified on the nameplate.

Depending on the model, a number of fittings and valves are found on the cooler (PIC. 3):

- **WATER PARTIALISATION VALVE (applicable depending on the model) (A PIC. 3):** Used to adjust the water supply to the cooler panel. A maximum water flow rate is obtained with the cock completely open (anticlockwise rotation of the knob).
- **WATER SUPPLY FITTING (B PIC. 3):** This is used for the continuous and automatic supply of water to the cooler (1/2" fitting and maximum inlet water pressure of 3 bar). After filling, it can also be moved, always with the utmost care.
- **MANUAL WATER SUPPLY COCK (C PIC. 3):** A water cock/hatch is present, which allows the tank to be filled manually.

NOTE: Take note of the maximum capacity of the tank in order to avoid overflows.

- **DRAIN COCK (D PIC. 3):** The base of the cooler has a drain cock, which is used to drain water from the tank.

4.1. SWITCH-ON:

4.1.1. Connect the cooler to the water mains using the threaded fitting (PIC. 4) and refill the water tank. When water in the tank reaches the maximum level, a float will automatically block the flow (it is possible to operate the cooler while being continuously connected and fed from water mains supply).
In case of manual refilling from the cock/hatch, pay attention to the tank's capacity in order to avoid overflows.

4.1.2. Check that there were no leaks during refuelling.

4.1.3. Connect the supply plug to the power mains.

4.1.4. Press ON/OFF / POWER to turn on the cooler (PIC. 5).

NOTE: When the cooler emits an acoustic beep, it means that the tank is empty and the device is operating in fan mode. To deactivate the acoustic beep, press the "COOL" button. Units with Firmware v.02 (showing at power up) will keep the water pump on for 15 minutes when there is no water, then it will show the "beep" acoustic warning and stop the pump.

4.2. FUNCTIONS OF THE CONTROL PANEL AND REMOTE CONTROL (PIC. 6):

- **ON/OFF/POWER:** Is used to turn the cooler on or off.
- **SPEED:** Increases or decreases the ventilation speed of the cooler. You can choose from three speeds.
- **COOL:** Enables or disables the cooling mode.
 - TIMER:** Enables to activate or deactivate the delayed switch-on or switch-off mode.
 - **Delayed switch-on:** With the cooler off, press the "TIMER" button several times until the intended number of hours is displayed, which flashes on the display (for example in no. 4, a countdown begins from 4 hours before automatic switch-on).
 - **Delayed switch-off:** With the cooler on, press the "TIMER" button several times until the intended number of hours is displayed, which flashes on the display (for example in no. 4, a countdown begins from 4 hours before automatic switch-off).
- **SWING (applicable depending on the model):** Enables or disables the automatic swing of the fins to direct the air flow.

4.3. SWITCH-OFF:

4.3.1. Press ON/OFF / POWER to turn off the cooler (PIC. 5).

4.3.2. Drain the tank through the specific drain cock (PIC. 7).

5. CLEANING AND MAINTENANCE

5.1. TANK:

IT IS RECOMMENDED TO READ THE SAFETY WARNINGS CAREFULLY AND TO CHANGE THE WATER FREQUENTLY.

5.1.1. Turn off the cooler and disconnect the plug from the power mains.

5.1.2. Drain the tank through the specific drain cock (PIC. 7).

5.2. EVAPORATIVE PANELS AND WATER CIRCUIT:

5.2.1. It is recommended to visually check the condition and correct position of the evaporative panels on a regular basis (PIC. 8). The panels must not be worn, damaged or encrusted and must be positioned correctly in order to avoid gaps between each other.

 **IMPORTANT:** Do not attempt to remove the evaporative panels. All operations must be carried out by the after-sales assistance service or with prior authorization following the guidelines shown below.

 **IMPORTANT:** Handle the evaporative panels with care; do not drill or insert pointed objects in the air inlet grille.

5.2.2. To ensure proper operation of the cooler, turn off the COOL mode a few minutes before completely switching off the cooler, in order to avoid stagnant water.

5.2.3. We recommend periodically performing a complete filling and draining cycle of the water circuit using clean water and appropriate disinfection products, running the cooler outdoors until the tank contents are emptied completely.

 **IMPORTANT:**

- The cooler tank must be emptied and sanitised periodically depending on the use.
- The evaporative panel surfaces must be periodically inspected and sanitised depending on the use.
- For sanitation operations, biocidal products that comply with European regulation

5.3. AIR FILTER (APPLICABLE DEPENDING ON THE MODEL) (PIC. 9):

 **WARNING:** A dirty air filter can lead to a significant drop in performance of the cooler.

IT IS RECOMMENDED TO CLEAN THE AIR FILTER OFTEN TO MAINTAIN THE COOLER IN GOOD CONDITION.

5.2.1. Turn off the cooler and disconnect the plug from the power mains.

5.2.2. Remove the fixing screws (if present) and remove the filter.

5.2.3. Clean the filter using a mild detergent and a soft cloth. Make sure that the filter is perfectly dry.

5.2.4. Refit the filter and secure it with the screws (if present).

7. TROUBLESHOOTING

FAULT	FAULT	SOLUTION
The display does not work	<ol style="list-style-type: none"> 1. No power supply. 2. Defective equipment. 	<ol style="list-style-type: none"> 1a. Make sure that the cooler is connected to the power supply. 1b. Contact a support centre. <ol style="list-style-type: none"> 2. Contact a support centre.
There is no air flow or it is very low	<ol style="list-style-type: none"> 1. Rear side air vent clogged. 2. Defective equipment. 	<ol style="list-style-type: none"> 1a. Keep the rear part of the cooler away from walls that may obstruct the airflow. 1b. Remove any objects from the air vent. 1c. Contact a support centre. <ol style="list-style-type: none"> 2. Contact a support centre.
The cooler does not respond to the commands	<ol style="list-style-type: none"> 1. Defective equipment. 	<ol style="list-style-type: none"> 1. Contact a support centre.
The cooler leaks water	<ol style="list-style-type: none"> 1. The drainage plug is loose. 2. The drain is dirty and the drainage plug does not fully close. 3. The tank leaks. 4. The panel is dripping. 	<ol style="list-style-type: none"> 1. Close the plug. 2. Clean the drain and close the plug. 3. Contact a support centre. 4. Contact a support centre.

8. TECHNICAL SPECIFICATIONS

	WF4	WF7	WF10
Nominal air flow rate	12.000 m ³ /h	22.000 m ³ /h	30.000 m ³ /h
Effective air flow rate	-	-	22.000 m ³ /h
Cooling capacity	80 dm ³	120 dm ³	340 dm ³
Coverage area	250 m ²	330 m ²	400 m ²
Power consumption	500 W	800 W	1.050 W
Voltage	220-240 V/50 Hz	220-240 V/50 Hz	220-240 V/50 Hz
Rated current	2,3 A	3,7 A	4,9 A
Fan (type)	Axial	Axial	Axial
Fan speed	3 speeds	3 speeds	3 speeds
Fan Ø / no. of blades	700 mm / 3 aspas	700 mm / 4 aspas	900 mm / 5 aspas
Water consumption	8-10 l/h	12-18 l/h	10-15 l/h
Water tank capacity	60 l	120 l	200 l
Direct water connection	½ inches	½ inches	½ inches
Water level sensor	Yes	Yes	Yes
Noise level	67 dB	67 dB	70 dB
Product size (l x w x h)	925 x 580 x 1430 mm	1130 x 690 x 1640 mm	1130 x 690 x 1640 mm
Shipping dimensions	1120 x 680 x 1650 mm	1300 x 720 x 1930 mm	1760 x 1000 x 2100 mm
Net/gross weight	50/55 kg	64/69 kg	130/140 kg
IP Protection	20	20	20

⚠ IMPORTANT: the equipment shall be connected to the mains with the same technical specifications as those indicated for the product.

9. PICTURES

PICTURE 1

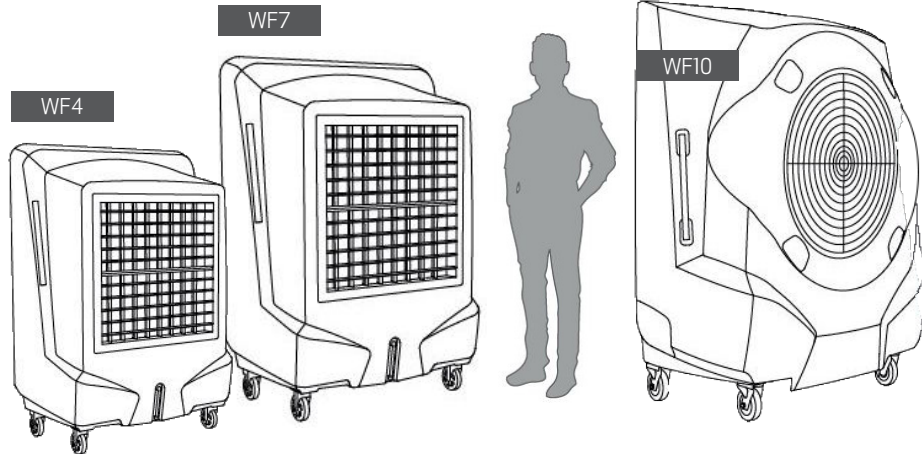

PICTURE 3

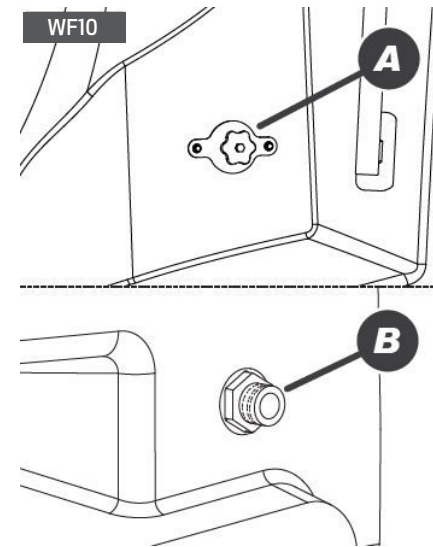

PICTURE 3

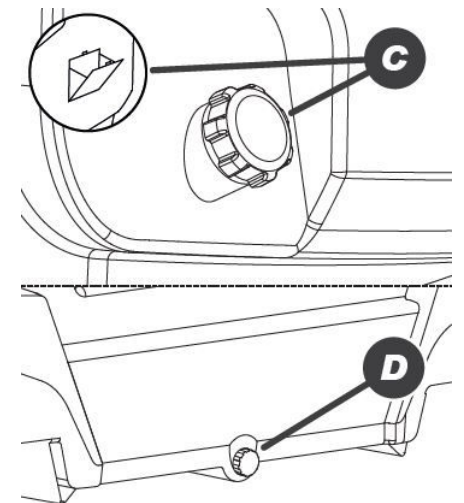

PICTURE 2

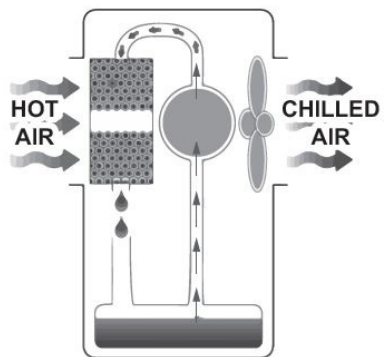

PICTURE 2

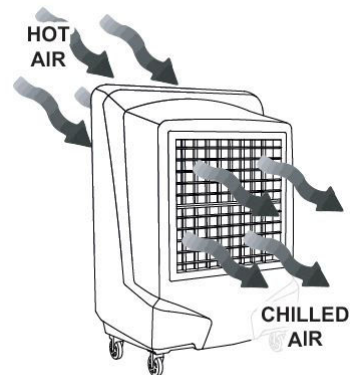

PICTURE 4

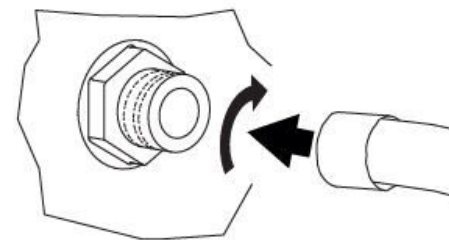

PICTURE 5



PICTURE 6

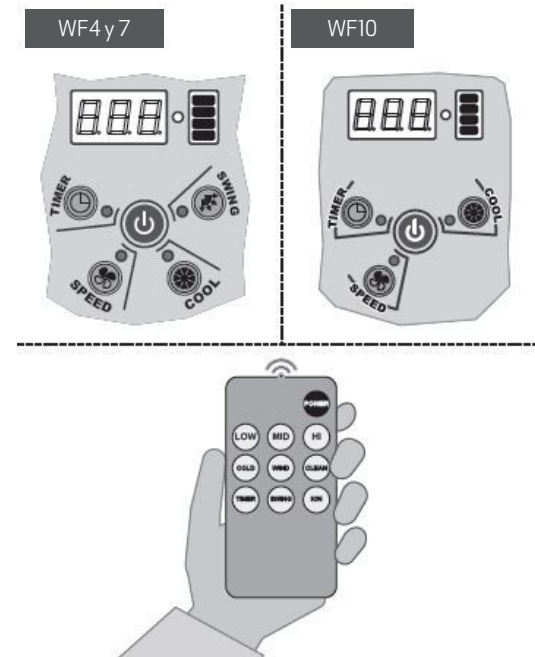

PICTURE 7

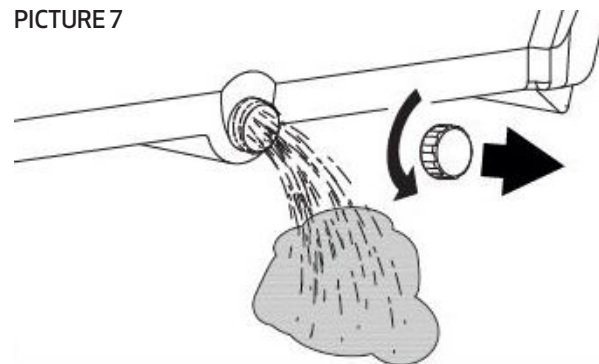

PICTURE 8

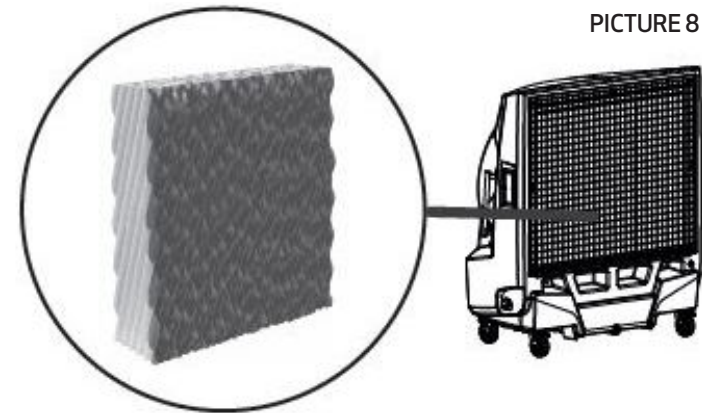

PICTURE 9

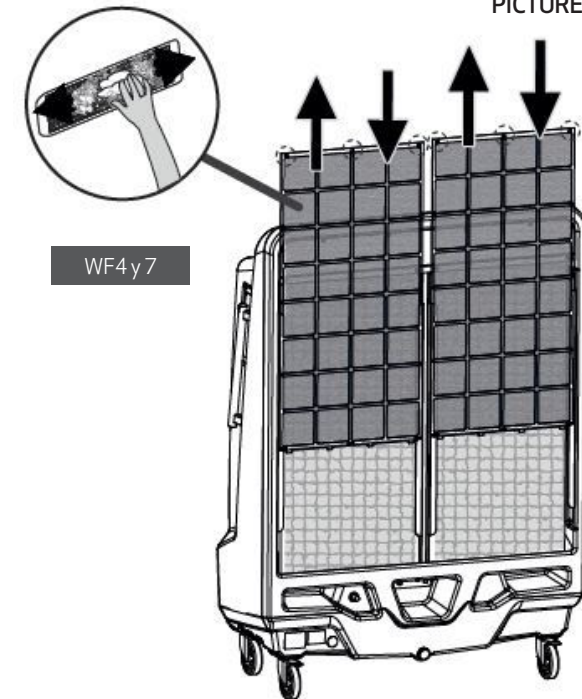

BIOCOOLERS

 **BIOCOOL**

ECO Cooling Solutions

Our company policy is one of continuous product improvement, therefore, all specifications are subject to change without notice.



2
GUARANTEE
COMPONENTS
YEARS

10
GUARANTEE
STRUCTURAL
YEARS

20
GUARANTEE
ANTI-CORROSION
YEARS